

SECTION A

NOTES

1. THE INTERNAL SURFACES MUST BE OF IMPERVIOUS MATERIAL.
2. THE SETTLEABLE SOLIDS ARRESTORS MAY BE CONSTRUCTED, PREFABRICATED OR PRECAST. HOWEVER, THE DESIGN MATERIAL USED AND SIZE IS TO BE EXAMINED BY TASWATER.
3. THE SETTLEABLE SOLIDS ARRESTOR IS TO BE LOCATED IN A POSITION SO AS TO PROVIDE READY ACCESS FOR MAINTENANCE AND INSPECTION PURPOSES.
4. WHERE A SETTLEABLE SOLIDS ARRESTOR IS TO BE INSTALLED OUTSIDE A BUILDING, CONSIDERATION SHOULD BE GIVEN TO FITTING AIRTIGHT COVERS, OF APPROPRIATE STRUCTURAL STRENGTH FOR WHERE PEDESTRIAN OR VEHICULAR TRAFFIC IS LIKELY, VENTING THE CHAMBER AND PROVIDE VENTING TO THE DISCONNECTOR GULLY.
5. DISPERSION BAFFLE SHALL BE MADE OF MATERIAL THAT DOES NOT DISTORT.
6. ALL MEASUREMENTS SHOWN ARE IN MILLIMETRES.

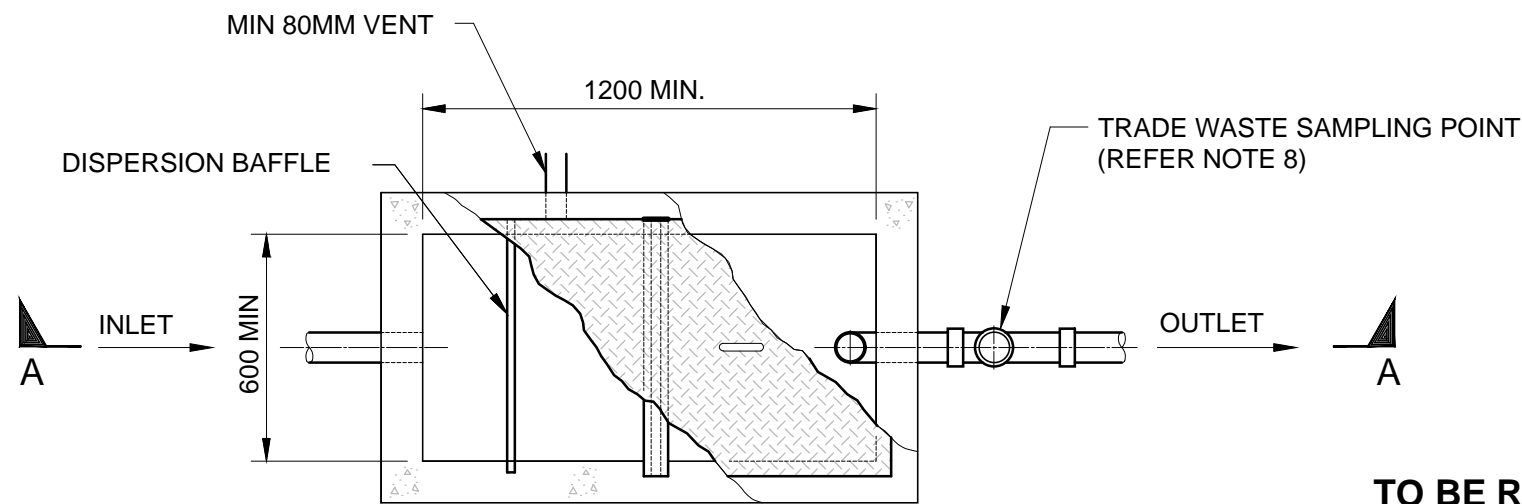

PLAN

TO BE READ IN CONJUNCTION WITH TASWATER PRETREATMENT GUIDELINES

**THESE STANDARD DRAWINGS ARE PROVIDED AS A GUIDE.
THE DESIGNER SHOULD ENSURE THAT THE PRETREATMENT SOLUTION IS
DESIGNED TO ENSURE COMPLIANCE WITH TASWATER DISCHARGE QUALITY
REQUIREMENTS AND ALL OTHER REGULATORY REQUIREMENTS**

Revision Notes				
1 - GENERAL UPDATE. SEE HPE RECORD NO. 19/136338				
B - INITIAL ISSUE				
Rev.	1	Date	13/11/19	Approved
				Greg Cooper



Scale	NTS
Datum	-
Sheet Size	A3
References	

Drawn	PH	24/9/2015
Designed	GC	24/9/2015
Verified	AD	6/10/2015
Project No.	-	Discipline
Vault Folder	© 2015	
HPRM File Ref.	T15/161-002-0001	

NOT FOR CONSTRUCTION

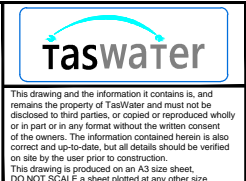

TASWATER STANDARD DRAWING			
TRADE WASTE TYPICAL DRAWING			
SETTLEABLE SOLIDS ARRESTOR			
TASMANIAN WATER & SEWAGE CORPORATION PTY LTD		ABN: 47 162220 653	
Sheet Number	TWS-C-0001	Revision	1