

TasWater Supplement to

WSA 02-2014-3.1

WSAA Gravity Sewerage Code of Australia
(Melbourne Retail Water Agencies Edition)

Version 2.0



Document approval and issue notice

This is a managed document. Changes will only be issued as a complete replacement document. Recipients should remove superseded versions from circulation. This document is authorised for release once all signatures have been obtained.

Prepared: (for release)	Glen Mackintosh Senior Engineer – Strategic Asset Management	Date: 17/05/2017
Endorsed: (for acceptance)	Matt Jordan Manager Network Asset Performance	Date: 17/05/2017
Endorsed: (for acceptance)	Grant Henderson Principal Engineer (Civil/Mechanical)	Date: 20/09/2017
Approved: (for acceptance)	David Graham Manager Asset Strategy	Date: 09/11/2017

Build status:

Version	Date	Author	Reason	Sections
1.0			Supplement to WSA-02-2002-2.3 MRWA Edition	
2.0	10/11/2017	GM	Supplement to WSA-02-2014-3.1 MRWA Edition	All

Amendments in this release:

Section title	Section number	Amendment summary

Distribution:

Copy number	Version	Issue date	Issued to

Table of contents

Document approval and issue notice	2
1. Introduction	6
PART 0: GLOSSARY OF TERMS, ABBREVIATIONS AND REFERENCES	7
I. GLOSSARY OF TERMS	7
II. REFERENCED DOCUMENTS	Error! Bookmark not defined.
PART 1: PLANNING AND DESIGN	8
2.4 PLANNING PARAMETERS	8
2.4.1 Loading per serviced property	8
2.4.2 Estimating future catchment loads	8
2.4.3 Estimating existing system loads	8
5.2 DETAIL DESIGN CONSIDERATIONS	8
5.2.4.8 Sewers located in road reserves	8
5.2.8 Easements	8
5.3 HORIZONTAL ALIGNMENT OF SEWERS	9
5.3.8 Horizontal curves in sewers	9
5.4 OBSTRUCTIONS AND CLEARANCES	9
5.4.4 Clearance from structures	9
5.4.5.2 Clearance requirements	9
5.5 PIPE SIZING AND GRADING	9
5.5.1 General	9
5.5.5 Maximum ET for reticulation sewers	9
5.5.5.2 Design Assumptions	10
5.6 VERTICAL ALIGNMENT OF SEWERS	11
5.6.2 Long section design plan	11
5.6.6.2 Internal fall through MHs joining sewers of same diameter	11
5.6.7 Vertical curves in sewers	11
5.6.8 Compound curves	11
6. PROPERTY CONNECTION	11
6.1 GENERAL	11
6.3 METHODS OF THE PROPERTY CONNECTION	11
6.3.2 IO interface method	11
6.3.3 Buried interface method	12

7	MAINTENANCE STRUCTURES	13
7.1	TYPES OF MAINTENANCE STRUCTURES	13
7.3	SPACING OF MAINTENANCE STRUCTURES	13
7.3.2	Maintenance structure spacing – Reticulation sewers	13
7.6	MAINTENANCE HOLES (MHs)	13
7.6.2	Types of MH construction	13
7.6.3	Design parameters for MHs	13
7.6.6	MH Drops	13
	TW requires all drops ≤ 225 to be internal.	13
7.6.7	Diameters of MHs	14
7.6.9	Ladders, step irons and landings	14
7.8	INSPECTION SHAFTS (ISs)	14
7.8.5.1	Temporary ends of pipe	14
7.9	MAINTENANCE STRUCTURE COVERS	14
7.9.1	General	14
9	STRUCTURAL DESIGN	14
9.3	STRUCTURAL CONSIDERATIONS	14
9.3.1	Pipes	14
9.9	PIPE COVER	14
10	DESIGN REVIEW AND DRAWINGS	15
10.2.1	General	15
10.5	RECORDING OF WORK AS CONSTRUCTED INFORMATION	15
	PART 2: CONSTRUCTION	16
12	GENERAL CONSTRUCTION	16
12.6	DISUSED SEWERS	16
13	PRODUCTS AND MATERIALS	16
13.1.	APPROVED PRODUCTS AND MATERIALS	16
17	MAINTENANCE HOLES (MHs)	16
17.2.2	Pre-cast concrete MH systems	16
17.2.6	Internal coating of concrete MHs	16
	MRWA 21.11 CCTV INSPECTION	16
25	WORK AS CONSTRUCTED DETAILS	17
	APPENDICES	18
	APPENDIX B: EQUIVALENT TENEMENT RATES	18
	APPENDIX C - FLOW ESTIMATION FOR UNDEVELOPED AREAS	22

C2 PEAK DRY WEATHER (SANITARY) FLOW	22
C4 RDI Calculation	22
C6 COMBINED SEWER DESIGN	22
4. PART 4: STANDARD DRAWINGS	23
4.1. Drawings Not Used	23
4.2. Drawings Modified	Error! Bookmark not defined.
4.3. Additional Drawings	Error! Bookmark not defined.
6. CHANGE LOG	24
7. DOCUMENT IMPROVEMENT REQUEST	25

1. Introduction

This supplement describes the requirements of TasWater (TW) for sewerage reticulation works which are an addition or a variance to those in the WSAA Gravity Sewerage Reticulation Code of Australia WSA-02-2014-3.1 MRWA Edition Version 2 (herein known as “the Code”). This supplementary document must be read in conjunction with the Code. As part of this update to the supplement of the Code, TasWater has further consolidated and aligned its requirements to the Code.

The Code and this supporting documentation essentially provides "deemed to comply" solutions for the creation of TW sewerage assets.

Alternative solutions, practices, equipment and methodologies will continue to evolve and offer opportunities to improve the creation of these assets. TW encourages employment of any innovation that offers enhanced productivity and serviceability.

Suggestions or comments using the document improvement request form are welcome and can be sent to: standards@taswater.com.au

PART 0: GLOSSARY OF TERMS, ABBREVIATIONS AND REFERENCES

I. GLOSSARY OF TERMS

Add

Authority/Owner/Water Agency Tasmanian Water and Sewerage Corporation trading as TasWater

TW Standards Nominated National Codes which may incorporate specific Tasmanian Water and Sewerage Corporations requirements for design and construction of infrastructure and the manufacture and supply of associated products and materials, and other documents including supplements to national Codes prepared and published or adopted by TW from time to time

Agreement conditions Means any conditions and requirements specified in the “TW Response to Council Notice of Planning Application Referral”, “TW Certificate of Certifiable Works”, the “Permit to Construct TW Infrastructure”, “Engineering Design Approval” and any “Approved Drawings”.

Rod Eyes Identical meaning to a Terminal (Type A) Inspection Shaft

Modified

Equivalent Tenement The equivalent hypothetical residential tenement that would produce the same **average dry weather flow** as that contributed by the area under construction i.e. all zonings including residential, commercial and industrial.

PART 1: PLANNING AND DESIGN

2.4 PLANNING PARAMETERS

2.4.1 Loading per serviced lot

Replace (c) with the following:

- (c) Equivalent Tenement (ET) per unit or per area rating, based on an assumed loading rating
- 450L/ET/day for new residences (post 2014)
 - 540L/ET/day for existing residences. (prior to 2014)

2.4.2 Estimating future catchment loads

Replace clause 2.4.2 with:

Increase in average daily loading shall be calculated as the product of the Estimated ET connected to the point of interest. Equivalent future tenements shall be calculated for each land use type to be developed by identifying the number of equivalent tenements to be developed from the table in Appendix B of this Supplement.

2.4.3 Estimating existing system loads

Replace paragraph 2 (Existing loads...) with:

Existing loads on ungauged areas shall be estimated as the sum of the products of unit numbers multiplied by ET/unit rates.

5.2 DETAIL DESIGN CONSIDERATIONS

5.2.4.8 Sewers located in road reserves

Replace first paragraph

Sewers located in road reserves shall comply with the requirements detailed by the road owner.

5.2.8 Easements

Table 111-C on Drawing MRWA-S-111 to be used for side boundary easements also. For easements outside the scope of Table 111-C the following shall be used to determine easement requirements.

Maximum Depth to Invert (m)	Nominal Pipe Size	Minimum Easement Width (m)
≤ 2.0	≤ DN225	3.0
	> DN225	4.0 or alternatively as advised by TW
> 2.0	≤ DN225	4.0
	> DN225	6.0 or alternatively as advised by TW

Noting that:

- The easement widths assume a single pipe located centrally in an easement.
- Sewers ≥ DN300 should wherever possible be located outside of private property.
- Easements may only be shared with stormwater pipes with clearances as per Section 5.4.5.2.
- The minimum clearance to the edge of the easement from the outside of the pipe shall be 1.0m. This may be reduced to 0.6m for ≤DN225 pipes where the depth to invert is ≤ 1.5m and where approved by TW.

- All MH's are to be located within the easement.
- TW's easements over piped infrastructure must not contain private underground services parallel with TW infrastructure. Approval must be sought for services within a TW easement other than customer sanitary drains that cross perpendicular +/- 15° to the TW infrastructure.
- Pipelines in road reserves shall be installed in accordance with Clause 5.2.4.8.

5.3 HORIZONTAL ALIGNMENT OF SEWERS

5.3.8 Horizontal curves in sewers

Generally, horizontal curves in gravity sewers are not permitted. Designers intending to incorporate horizontal curves should provide a construction management plan, that forms part of the engineering sewer design plan submitted for approval by TW.

5.4 OBSTRUCTIONS AND CLEARANCES

5.4.4 Clearance from structures

- Clearances from structures will be in accordance with TW's "Guidelines for Building Near Water and Sewer Pipelines"

5.4.5.2 Clearance requirements

Note 3 associated with Table 5.4 is deleted.

5.5 PIPE SIZING AND GRADING

5.5.1 General

Add to clause:

The Designer may undertake calculations based on Colebrook-White Formula for pipes flowing partially full using the design criteria outlined in the Code, this Supplement and *Appendix C - Flow Estimation For Undeveloped Areas* to satisfy the requirements of the Code.

5.5.5 Maximum ET for reticulation sewers

Table 5.6 specifies maximum and minimum lots for the Melbourne area. This table can be used for all Tasmanian areas as 'deemed to comply' other than the Systems detailed below in Table 5.6.A where a reduction factor to the number of Maximum Lots/Area must be applied as outlined:

Sewerage System	Table 5.6 Maximum Lot/Area Reduction Factor
Scamander St Helens St Marys Stieglitz	20%
Bicheno Ansons Bay Boat Harbour Burnie Fingal Ridgley Sheffield Somerset Turners Beach Ulverstone Wynyard	10%

Table 5.6.A

5.5.5.2 Design Assumptions

When utilising Appendix C the following default values shall be utilised unless approved otherwise by TW:

k	1.50	mm	
d/D	0.7		
EP/ET	3.00		
Industrial/Commercial	75	EP/Ha	
ADWF	150	L/d/EP	new residences (post 2014)
	180	L/d/EP	existing residences (prior to 2014)
Median lot Area	700	m ²	
Net/Gross lot area	70%		
Sewer below water table	70%	Portion _{Wet}	
Soil aspect	0.8	S _{aspect}	See Note 1 below
Network defects aspect	0.6	N _{aspect}	
Leakage severity, C	1.4	S _{aspect} + N _{aspect}	See Note 1 below
ARI	5	years	
Portion _{Impervious}	0.2		Default value of 0.2 unless known

Note 1:

The default for Soil Aspect is 0.8 unless justification can be supplied to lower this value by a qualified geotechnical specialist. The table below outlines appropriate values that can be used. A soil test must be undertaken, with the test depth exceeding the invert of the sewer main by approximately 300mm to satisfy this requirement..

Influencing Aspect	Low Impact	Medium Impact	High Impact
Soil aspect(S _{aspect})	0.4	0.6	0.8
Description	Soils with good drainage	Soils with moderate drainage	Soils with poor drainage

Table 5.5.5.2

5.6 VERTICAL ALIGNMENT OF SEWERS

5.6.2 Long section design plan

Add to clause:

The longitudinal sections shall, as a minimum, show the following information:

- Chainages
- Manhole cover level, invert level, depth and surface level adjacent to each manhole
- Pipe material, nominal diameter, jointing, class and gradient
- Bedding and backfill materials
- Existing and final surface levels, including roads
- Existing services including service type, diameter (where known), and invert levels. Any assumed invert levels should be explicitly stated.
- Property connections and details – including Control invert levels, surface level, depth and property connection type

5.6.6.2 Internal fall through MHs joining sewers of same diameter

Whilst a minimum drop is indicated in MRWA-S-307, deflections >90° are by approval only and greater than 120° are not permitted.

5.6.7 Vertical curves in sewers

Long radius curves are not preferred but may be accepted with approval of the Water Agency. Short bends are not permitted.

5.6.8 Compound curves

Not accepted.

6. PROPERTY CONNECTION

6.1 GENERAL

Add to clause:

The Developer must obtain written approval and conditions of connection from TW for connection to TW's sewerage system.

6.3 METHODS OF THE PROPERTY CONNECTION

6.3.2 IO interface method

Add to clause:

Approved for use by the Water Agency.

For the IO interface method, property connection sewers must be constructed with sufficient horizontal straight pipes so that the property connection fitting is wholly within the lot to provide a point of connection for the customer sanitary drain. An IO, constructed as part of the Water Agency property connection sewer, defines the change of ownership from Water Agency to lot Owner. The

Water Agency owns the surface IO and the property connection sewer downstream of the IO. The lot Owner is responsible for providing and maintaining the sanitary drain upstream of the IO in accordance with AS/NZS 3500.2.

The property connection sewer should be at the required depth to service the lot. Figure 6.1 shows a typical Type 1 property connection assembly using a raised inspection (IO) interface method.

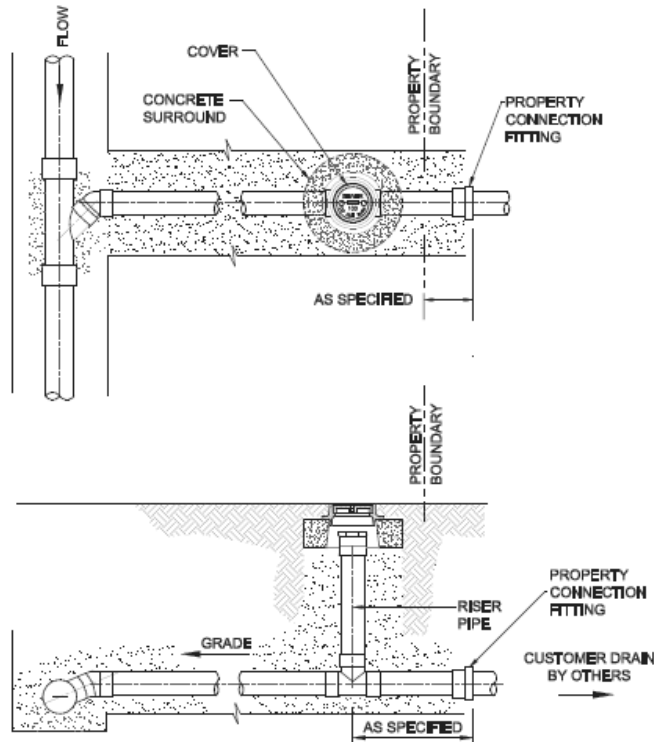

FIGURE 6.1 TYPICAL RAISED INSPECTION OPENING INTERFACE METHOD

6.3.3 Buried interface method

Not approved for use by the Water Agency. *Delete Clause.*

7 MAINTENANCE STRUCTURES

7.1 TYPES OF MAINTENANCE STRUCTURES

Replace with the following clause

This WSAA Code addresses five (5) types of maintenance structures:

- a) Maintenance holes (MHs), which are applicable to all sewer sizes and allow personnel and equipment access to the sewer system and have a minimum ID of 1.0m. **MHs are permitted for use by TW.**
- b) Maintenance chambers (MCs), which are currently only applicable to DN 100 property connections and ≤DN 375 sewers with nominal DN 600 shaft and only allow equipment access to the sewer system. **MCs are not permitted for use by TW.**
- c) Maintenance shafts (MSs), which are currently only applicable to DN 100 property connections and ≤DN 225 sewers with nominal DN 225 or DN 300 shaft and only allow equipment access to the sewer system. **MSs are not preferred by TW but may be permitted with TW approval.**
- d) Not used; and
- e) Inspection shafts (ISs), which are terminal maintenance structures with nominal DN 150 or DN 225 riser that provide limited access to the sewer. It is assumed that any maintenance will generally be done from the downstream maintenance structure. **IS are permitted for use by TW, but only with approval.**

Note:

- Change in grade and horizontal direction are not permitted through a MS.

7.3 SPACING OF MAINTENANCE STRUCTURES

7.3.2 Maintenance structure spacing – Reticulation sewers

The maximum distance between maintenance structures is:

- 150m between successive MH's with multiple MS in between
- 90m between a MH and MH/MS; and
- 45m between a MH and IS.

7.6 MAINTENANCE HOLES (MHs)

Where possible, preference will be given to conical top MHs, unless specified in Table 313-A

7.6.2 Types of MH construction

TW will only accept cast in-situ concrete and pre-cast concrete MHs. Construction of MHs from alternative materials, such as PE or other plastic materials, is not permitted without prior approval from TW.

7.6.3 Design parameters for MHs

Precast concrete MHs are not approved for use in water charged ground, areas subject to surcharge, where greater than 6m in depth to invert below top of manhole or on surcharged sewers.

Note that External Drops are not permitted for use without prior written approval and if approved may require the manhole to be cast in-situ.

7.6.6 MH Drops

TW requires all drop pipes ≤DN225 to be internal.

7.6.7 Diameters of MHs

The minimum diameter of maintenance holes shall be in accordance with Table 7.6.7. For any size greater than this, a design must be provided, and prior approval be obtained from TW.

No. of Internal Drops	Minimum Manhole Diameter mm by Sewer Size	
	≤DN225	≥DN300
Nil	1050	1200
1	1050	1200
≥2	1500	1500

Table 7.6.7

Where the depth of the manhole is $\geq 4.0\text{m}$ then the size of the manhole will need to be considered on a case by case basis.

7.6.9 Ladders, step irons and landings

Entry into a MH is a confined space entry, and sufficient access to the MH must be provided to allow for the set up of equipment required for confined space entry.

7.8 INSPECTION SHAFTS (ISs)

7.8.5.1 Temporary ends of pipe

This clause applies to sewers that are to be or have the potential to be extended in future.

Temporary end of pipes shall be terminated with an inspection shaft.

7.9 MAINTENANCE STRUCTURE COVERS

7.9.1 General

Add clauses

All covers shall be watertight and gas tight for all locations.

Covers and frames to be greased with Manhole Sealing Grease, upon installation.

9 STRUCTURAL DESIGN

9.3 STRUCTURAL CONSIDERATIONS

9.3.1 Pipes

Add to dot point a)

Requirements for elastomeric seals in gravity and rising main pipes:

- For domestic wastes only – EPDM, SBR or CR
- For industrial or commercial wastes – CR only

9.9 PIPE COVER

Add clause

TW requires the designer to submit calculations for all sewers where the depth to the top of the pipe exceeds 3m in trafficable areas and 4m in non-trafficable areas. These calculations shall demonstrate sufficiency of the strength of the proposed pipe type and trenching conditions.

10 DESIGN REVIEW AND DRAWINGS

10.2.1 General

The top right hand corner of every drawing sheet is to include provision for a TW signature endorsing approval of the drawing.

10.5 RECORDING OF WORK AS CONSTRUCTED INFORMATION

Work As Constructed drawings shall be provided in the same format as the Design Drawings.

TW requires that asset spatial data and attributes be captured and provided in 'digital ready format' in accordance with the latest edition of TW's Asset Data Specification. This is to enable efficient input of the asset data into TW's GIS and Asset Management Information System.

For further information on TW's Asset Data Specification refer to: www.taswater.com.au > Development > Development Standards

PART 2: CONSTRUCTION

12 GENERAL CONSTRUCTION

12.6 DISUSED SEWERS

Add clause

Where sewer pipes are no longer required they shall either be:

- Removed if less than 1m deep to obvert, or
- Fully filled with flowable grout

13 PRODUCTS AND MATERIALS

13.1. APPROVED PRODUCTS AND MATERIALS

Add clause

Unless otherwise specifically agreed, the only products to be used are those endorsed in the CWW list which is available from the MRWA website:

<http://www.mrwa.com.au/Pages/Products.aspx>

17 MAINTENANCE HOLES (MHs)

17.2.2 Pre-cast concrete MH systems

MH Precast Concrete Sections with inbuilt penetrations for step irons may be approved provided that the unused penetrations are scabbled and filled with non-shrink epoxy grout.

Joints shall be sealed using mastic (adhesive mastic impregnated carrier backed with PVC laminate).

17.2.6 Internal coating of concrete MHs

The internal exposed surfaces of rising main receiving manholes shall be prepared and coated with an approved lining or protective coating in accordance with "WSA 201—2017 Manual for selection and application of protective coatings - Second Edition Version 2.1"..

TasWater preference is for use of an approved epoxy resin for internal sealing of maintenance holes from the following:

Waste Source	Epoxy Resin
Domestic only	<ul style="list-style-type: none">• Epirez 133 with Epirez Epoxy Mortar Aggregate Extender• Parchem Nitromortar EL (min 5mm) or Nitromortar ELS (min 3mm)
Industrial or Commercial	<ul style="list-style-type: none">• Epirez 133AR with Epirez Epoxy Mortar Aggregate Extender

Alternative coatings provided in WSA 201 for this application, may considered but will be required to be approved as part of the submitted design before use.

21.11 CCTV INSPECTION

A CCTV inspection shall be undertaken for all sewers \geq DN150 with a minimum length of 20m at the end of the maintenance period and an inspection report shall be provided in accordance with the requirements of the latest edition of WSA 05-2013 V3.1 Conduit Inspection Reporting Code of Australia.

25 WORK AS CONSTRUCTED DETAILS

Work As Constructed drawings shall be provided in the same format as the Design Drawings.

TW requires that asset spatial data and attributes be captured and provided in 'digital ready format' in accordance with the latest edition of TW's Asset Data Specification. This is to enable efficient input of the asset data into TW's GIS and Asset Management Information System.

For further information on TW's Asset Data Specification refer to: www.taswater.com.au > Development > Development Standards

APPENDICES

Appendices are linked to WSAA website from within the WSA-02 2014-3.1 (MRWA Edition). The following amendments will be included in those appendices.

APPENDIX B: EQUIVALENT TENEMENT RATES

All sections of Appendix B Estimation Of Equivalent Population (EP) including Table B1, Table B2 and Table B3 shall be deleted in their entirety and replaced with following.

The equivalent tenement rates contained within the following Table B1 shall be utilised.

ET Code	Development Type	Water	Sewer	Units
RC	Subdivision			
RC01	Creation of new lot 300m2	1	1	Lot
RC02	Creation of new lot <450m2	1	1	Lot
RC03	Creation of new lot 450 <2000m2	1	1	Lot
RC04	Creation of new lot 500m2	1	1	Lot
RC05	Creation of new lot 1000m2	1	1	Lot
RC06	Creation of new lot >2000m2	1	1	Lot
RC07	Creation new lot	1	1	Lot
	Residential dwellings:			
RE	Standard Occupancy			
RE01	Single dwelling any size lot	1	1	Dwelling
	Multiple Occupancy Medium Density - 1-2 Storeys			
RM				
RM01	Unit - 1 bedroom	0.4	0.5	Dwelling
RM02	Unit - 2 bedroom	0.6	0.75	Dwelling
RM03	Unit - 3+ bedroom	0.8	1	Dwelling
	Multiple Occupancy High Density - >2 Storeys			
RA				
RA01	Apartment - 1 bedroom	0.33	0.5	Dwelling
RA02	Apartment - 2 bedroom	0.5	0.75	Dwelling
RA03	Apartment - 3+ bedroom	0.67	1	Dwelling
	Accommodation (Permanent)			
AP				
AP01	Nursing home / Special care home	0.657	0.971	Bed
AP02	Self Care Retirement Units / Villas	Use Unit Rate	Use Unit Rate	Dwelling
AP03	Self Care Retirement - Serviced Unit (On-site)	0.5	0.75	Dwelling
AP04	Self Care Retirement - Serviced Unit (Off-site)	0.3	0.45	Dwelling
AP05	Boarding house	0.33	0.5	Bed
AP06	Caravan / Mobile Home Park - 1 bedroom	0.4	0.5	Van

ET Code	Development Type	Water	Sewer	Units
AP07	Caravan / Mobile Home Park - 2 bedrooms	0.6	0.75	Van
AP08	Caravan / Mobile Home Park - 3+ bedrooms	0.8	1	Van
AS Accommodation (Short Term)				
AS01	Caravan Park - Caravan/Cabin/Camping site (temporary)	0.5	0.6	Site
AS02	Bed & Breakfast / Guest House	0.4	0.5	Room
AS03	Services - Motel / Hotel / Resort Room - medium density	0.3	0.45	Room
AS04	Services - Motel / Hotel / Resort Room - high density (low end)	0.3	0.45	Room
AS05	Backpackers / Hostel	0.15	0.23	Bed
AS06	Serviced/unserviced apartments	Use Apartment Rate	Use Apartment Rate	Dwelling
AM Accommodation (Medical Care)				
AM01	Hospital	0.622	0.971	Bed
AM02	Hostel (Medical)	0.622	0.971	Bed
BE Business (Excluding food preparation)				
BE01	Single retail shop	0.002	0.003	GBFA(sqM)
BE02	Supermarket	0.002	0.003	GBFA(sqM)
BE03	Shopping centre	0.0013	0.002	GBFA(sqM) [WSAA 0.002 GBFA sqM applied unless determined otherwise on a case-by-case analysis]
BE04	Office	0.004	0.006	GBFA(sqM)
BE05	Hairdresser / Beauty Salon	0.5	0.8	Basin
BE06	Laundromat	0.45	0.7	Machine
BE07	Medical Centre	0.4	0.6	Room
BE08	Service Station	0.6	0.9	Lane
BE09	Car Wash (Wand Wash)	1.442	2.247	Wand
BE10	Car Wash (Drive Through)	5.7	9	Lane
BE11	Animal Boarding	Case-by-case	Case-by-case	Case-by-case
BE12	Self Storage	0.004	0.006	GBFA(sqM) - Office area only
BE13	Nursery	Case-by-case	Case-by-case	Case-by-case

ET Code	Development Type	Water	Sewer	Units
BE14	Airport	Case-by-case	Case-by-case	Case-by-case
MP	Meal Preparation			
MP01	Restaurant/Café	0.005	0.008	GBFA(sqM)
MP02	Take Away/Fast Food no public amenities	0.015	0.024	GBFA(sqM)
MP03	Take Away/Fast Food including public amenities	0.03	0.048	GBFA(sqM)
MP04	Catering	0.005	0.008	GBFA(sqM)
FM	Food Manufacture			
FM01	Meat - Abattoir/Smallgoods	0.064	0.064	GBFA(sqM)
FM02	Dairy - Milk	0.160	0.160	GBFA(sqM)
FM03	Dairy - Cheese, Butter, Yoghurt	0.096	0.096	GBFA(sqM)
FM04	Dairy - Ice Cream	0.032	0.032	GBFA(sqM)
FM05	Grain - Flour Milling/Bakery	0.0016	0.0016	GBFA(sqM)
FM06	Grain - Biscuits & Cakes	0.016	0.016	GBFA(sqM)
FM07	Beverages - Beer	0.064	0.064	GBFA(sqM)
FM08	Beverages - Soft drinks & Cordials	0.032	0.032	GBFA(sqM)
FM09	Others - Confectionery	0.008	0.008	GBFA(sqM)
TL	Textile & Leather			
TL01	Wool - Wool scour	0.128	0.128	n/a
TL02	Wool - Felt & Carpet, Dyeing & Spinning	0.032	0.032	n/a
MM	Metal Processing & Manufacturing			
MM01	Factory/Workshop	0.004	0.004	GBFA(sqM)
MM02	Metal Finishing - Electroplating, Anodising, Galvanising	0.032	0.032	GBFA(sqM)
MM03	Engineering - Machine Shops, Sheet Metal, Foundry, Extrusion	0.016	0.016	GBFA(sqM)
MM04	Engineering - Rolling	0.016	0.016	GBFA(sqM)
MM05	Manufacturing - Concrete Products	0.064	0.064	GBFA(sqM)
SL01	Services			
SL01	Services - Laboratories	0.064	0.064	GBFA(sqM)
SL02	Services - Laundries - Industrial	0.24	0.24	GBFA(sqM)
EF	Entertainment			
EF01	Licensed Club	0.045	0.071	Occupant
EF02	Pub / Bar	0.03	0.048	GBFA(sqM)
EF03	Cinema / Theatre / Public	0.009	0.014	Visitor

ET Code	Development Type	Water	Sewer	Units
	Entertainment			
EF04	Conference Centre	0.009	0.014	Visitor
EF05	Marina	0.6	0.9	Berth
SF	Sporting / Spectator Facilities			
SF01	Sports stadium	Case-by-case	Case-by-case	Case-by-case
SF02	Amenities & Indoor Facilities	Case-by-case	Case-by-case	Case-by-case
SF03	Hockey Field - artificial surface	Case-by-case	Case-by-case	Case-by-case
SF04	Sports ground irrigated area	Case-by-case	Case-by-case	Case-by-case
SF05	Bowling Alley	0.35	0.55	Lane
SF06	Bowling Green	Case-by-case	Case-by-case	Case-by-case
SF07	TW-Simming Pool - Indoor/Outdoor	Case-by-case	Case-by-case	Case-by-case
CF	Community Facilities			
CF01	Child Care Centre/Pre-school	0.06	0.1	Person
CF02	Education - School (primary & secondary)	0.037	0.057	Student
CF03	Education - College, University (tertiary)	0.037	0.057	Student
CF04	Correctional Centre	0.5	0.75	Person
CF05	Church / Place of Worship	Case-by-case	Case-by-case	Case-by-case
CF06	Community Centre/Hall	Case-by-case	Case-by-case	Case-by-case
CF07	Parks / Gardens / Reserves	n/a	0.001	GrossArea(sqM)
CF08	Public amenities Block (per shower)	0.4	0.6	Shower
CF09	Public amenities Block (per wc)	0.4	0.6	WC
	Trade Waste (Non-Domestic Sewage)			
TW	Biological loading exceeding domestic sewage	Case-by-case	Case-by-case	Case-by-case

Table B1

APPENDIX C - FLOW ESTIMATION FOR UNDEVELOPED AREAS

https://www.wsa.aasn.au/sites/default/files/publication/download/Appendix%20C_Flow%20Estimation%20for%20Undeveloped%20Areas_MRWA.pdf

C2 PEAK DRY WEATHER (SANITARY) FLOW

Replace with the following

As detailed in 2.4.1 *Loading per serviced property* of this Supplement, loading rates are based on Equivalent Tenements. Therefore ADWF and PDWF shall be calculated as:

- $ADWF (L/s) = ET * \text{loading rate (450 or 540 L/ET/day)} * 0.0067$
- $PDWF (L/s) = d * ET * \text{loading rate (450 or 540 L/ET/day)} * 0.0067$

The Loading Rate shall be in accordance with the requirement outlined in 2.4.1 of this Supplement.

C4 RDI Calculation

1 Hour duration rainfall intensity for an ARI of 2 years, $I_{1,2}$

Rainfall intensities for particular locations may be determined from the Bureau of Meteorology at <http://www.bom.gov.au/water/designRainfalls/revised-ifd/>

The latest IFD's shall be used with the 50% Annual Exceedance Probability (equivalent to the 2 year ARI).

Coordinates for particular locations for use in the Bureau of Meteorology's site may be found at <http://www.ga.gov.au/place-name/>

C6 COMBINED SEWER DESIGN

New Clause

Where possible, all extensions to a combined sewerage network should be designed as separated stormwater and sewerage.

4. PART 4:STANDARD DRAWINGS

4.1. Drawings Not Used

The following drawings have been deleted:

SEW1154-M and replaced with SEW-1106, which is used by TW

6. CHANGE LOG

Date	Rev No	Section	Details

7. DOCUMENT IMPROVEMENT REQUEST

DOCUMENT IMPROVEMENT REQUEST			
TW's Supplementary Manual to WSA 02-2014 Version 3.1 MRWA			
FROM: Name:			
Position/Title:			
Section/Company:			
Address:			
Email:		Phone:	
Signature:		Date:	
TO: Senior Engineer Strategic Asset Management, TasWater			
Email: standards@taswater.com.au			
SUGGESTED IMPROVEMENT			
Part	Clause	Page No	Proposed Improvement & Justification

